



Flexware®

A Veteran & Employee Owned Small Business



AWM

Asset Web Monitor

Data Monitoring – Analysis - Trending - Forecasting – Diagnostics – Engineering Solutions



Providing Turbomachinery Services for over 25 Years

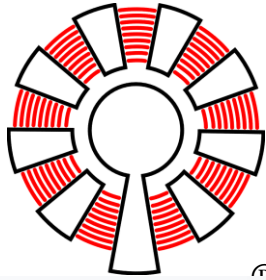

Flexware®



Asset Web Monitor (AWM) is a platform that **brings together all the information** from predictive diagnostic systems **to an single environment accessible from any location**

Eliminate information-access problems of access to information, while providing the analyst with powerful tools for diagnostics and generation of predictive reports.

**Data Monitoring – Trending -
Forecasting – Diagnostics –
Engineering Solutions**

AWM, a single diagnostic platform that brings together all the information needed for a predictive maintenance plan for monitoring in the cloud.





Flexware®



- ◆ **AWM makes condition monitoring easy by:**
 - **Collecting all the equipment operating data**
 - **Storing and processing the equipment data in the cloud**
 - **Trending and forecasting the data trends**
 - **Organized, consolidated data at your finger tips**
 - **Detecting any possible developing fault at an early stage**
 - **Diagnostics of it's origin offers solutions to pending issues**
 - **Flexware engineering staff available for support**
 - **Trending aids scheduling maintenance**
 - **Avoid unexpected shutdowns**



Flexware®

A Veteran & Employee Owned Small Business



➤ **Condition Based Maintenance:**

- Is a comprehensive predictive maintenance program
- Reduces the cost of maintenance
- Reduces repair downtime
- Longer machine life
- Increased production of plant
- Improves plant profits

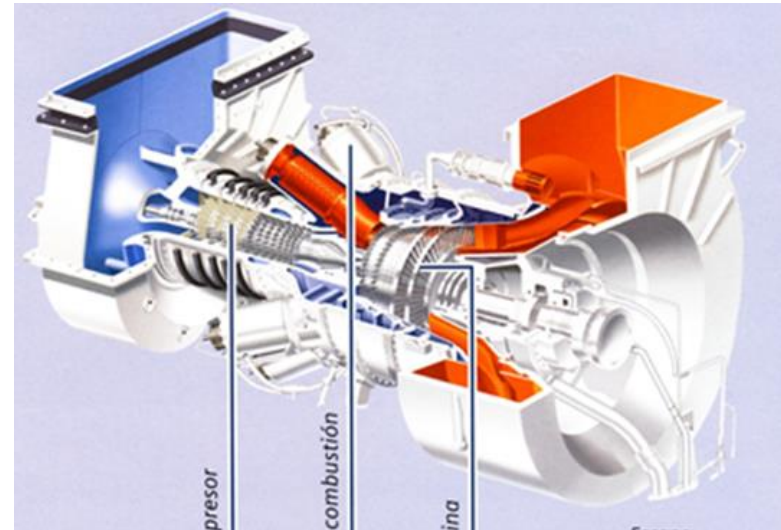



Flexware®

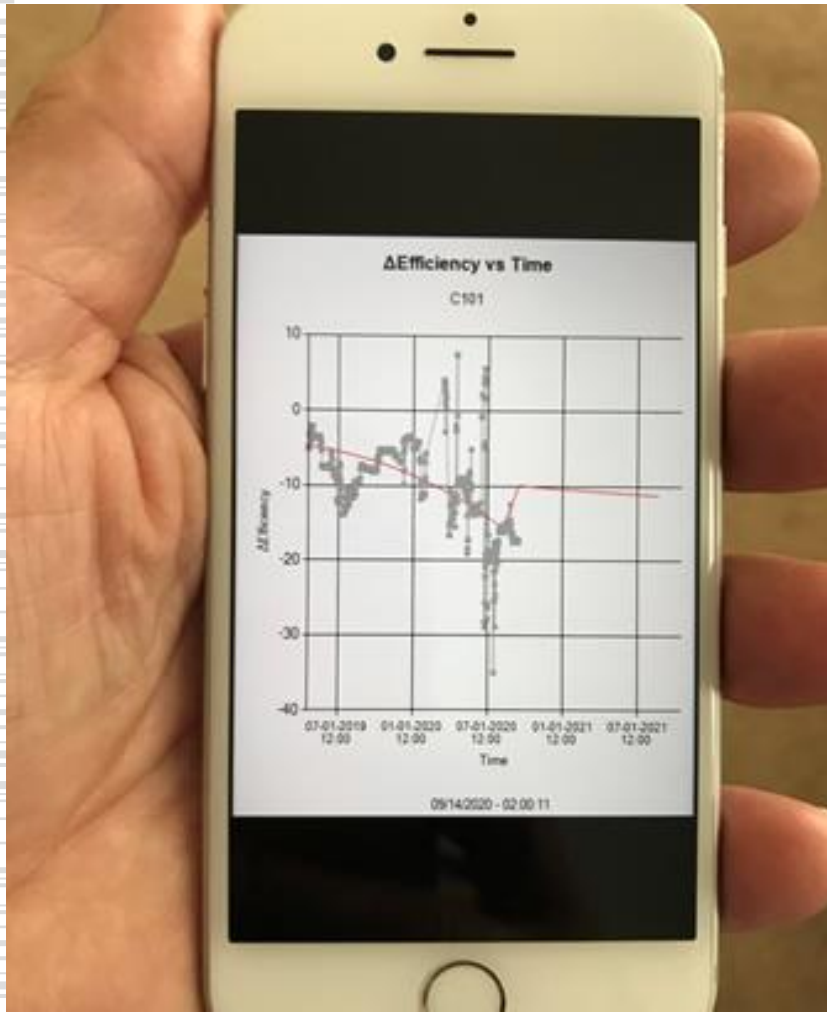

Turbomachinery health is best assessed by trending and forecasting and collectively assessing:

- ◆ Delta efficiency (efficiency deviation from predicted values)
- ◆ Vibration
- ◆ Bearing temperatures
- ◆ Seal operating data
- ◆ Oil analysis

Functionalities

1. Access to the **health status** of critical assets
2. **Automation** of predictive diagnostic monitoring
3. **Graphics and supervisory functions**, single panel
4. Powerful **predictive diagnostic tools**
5. More efficient **alarm management** (statistical alarms)
6. **Multi-technique, multi-technology, multi-site and multi-user**
7. **Easy access** to information, dashboards, historian, etc.
8. **Recording of diagnosed failures**
9. Facilitates digitization of the company (**Industry 4.0**)
10. **Integration** of information with existing systems: DCS, SCADA, EAM, CMMS, etc.
11. Based on **big data and predictive analytics** technologies

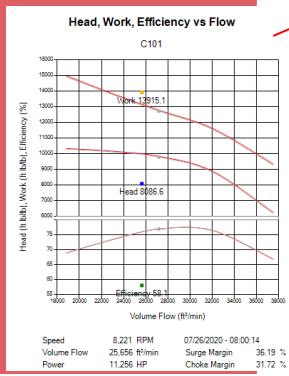

PERFORMANCE

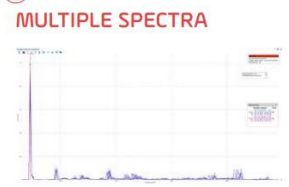
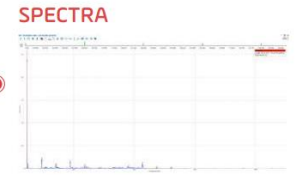
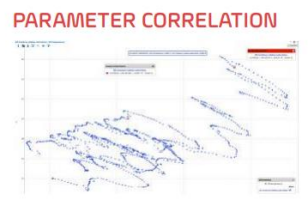
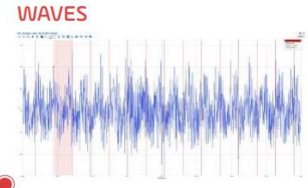
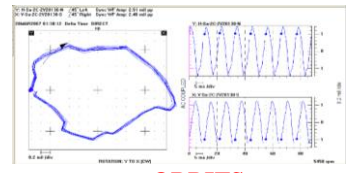
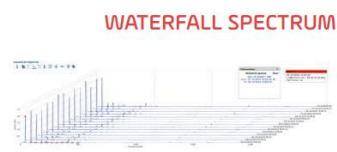
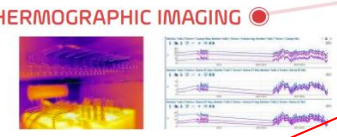
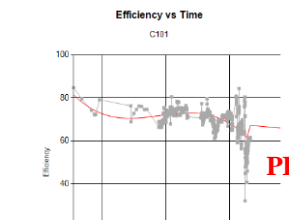

PERFORMANCE TRENDING & FORECASTING



Flexware®

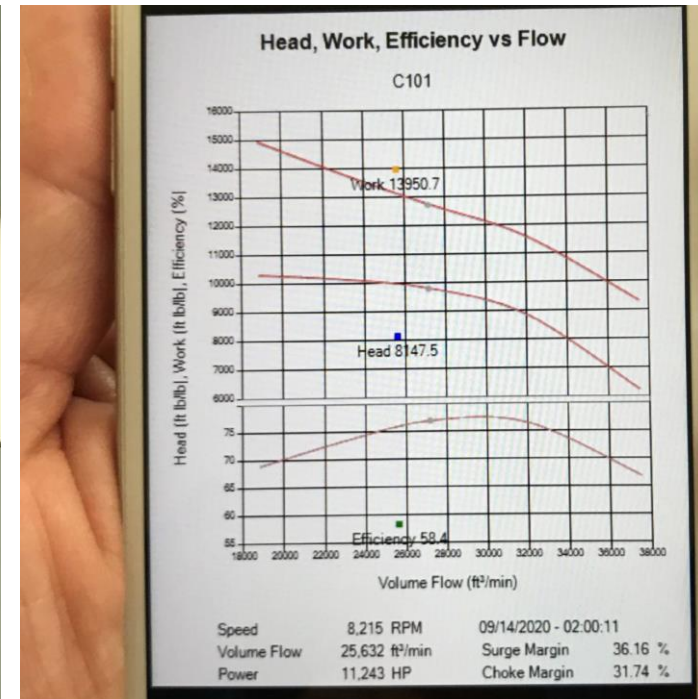
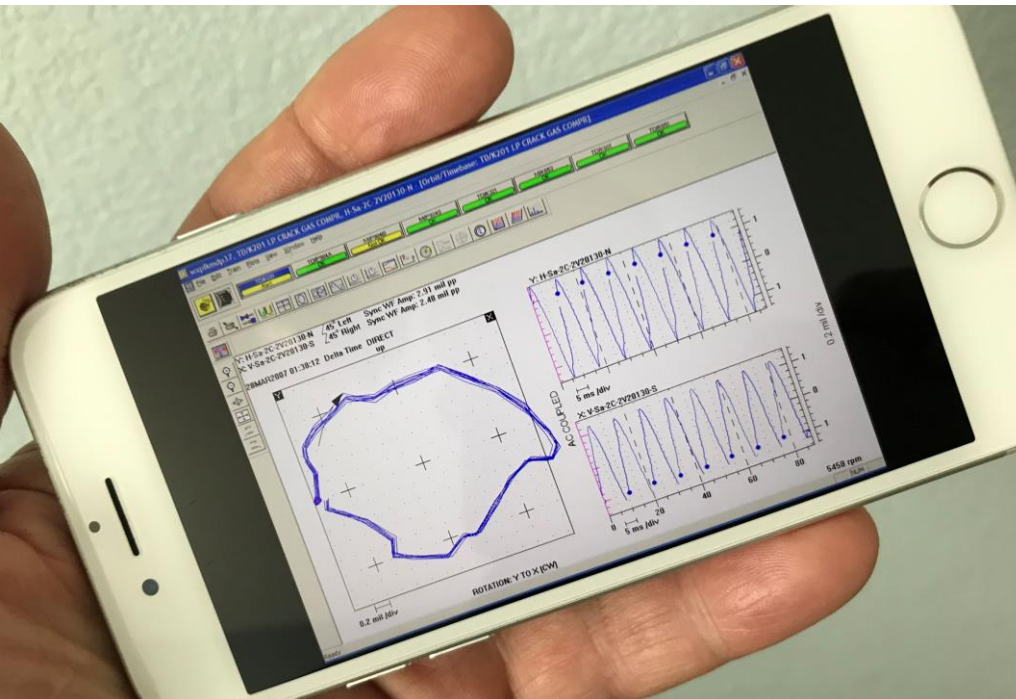

Since the AWM system is in the cloud, equipment health issues and diagnostics are at your fingertips.



Flexware®



Asset Web Monitor

- Cloud Condition Monitoring
 - Vibration & Performance
 - Bearings & seals
 - Oil analysis
 - Pressures & Temperatures and other Data
- Rotating Machinery
 - Centrifugal & Axial Compressors
 - Reciprocating Compressors
 - Gas & Steam Turbines
 - Pumps
- Predictive Diagnostics
 - AI – big data
 - Rotating Machinery Experts
 - Vibration Specialists
 - Aerodynamicists

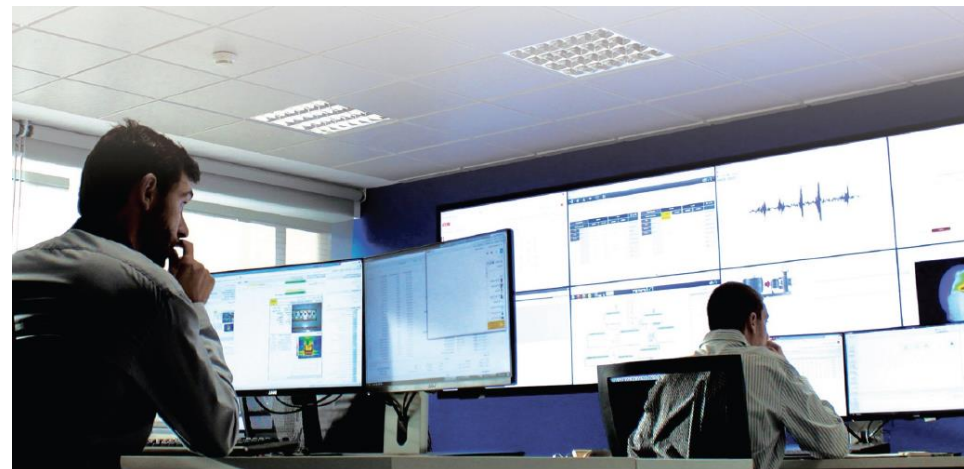
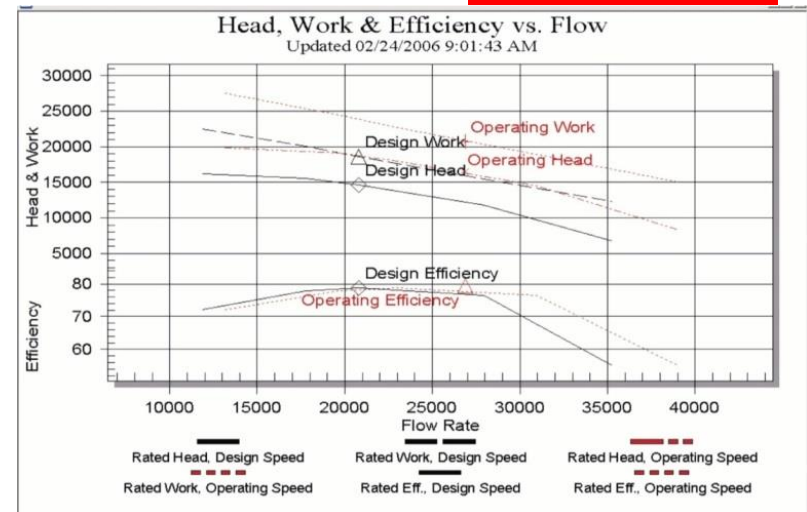

Applications

*Steam, gas, hydraulic and wind turbines
Rotary, screw and reciprocating compressors
Gearboxes and multipliers
Electric motors and generators
Centrifugal pumps
Fans and blowers
Rotary mills and furnaces
Shakers, mixers, etc. Cooling towers
Machine tool
Reciprocating engines
Centrifuges
Cranes*



AWM
Asset Web Monitor



AWM
Asset Web Monitor



AWM
Asset Web Monitor



Flexware® Experience

- ◆ Broad based industry experience
- ◆ Large group of international customers
- ◆ OEM: development, design, & service
- ◆ User: operation, maintenance



Petrochemicals
Industrial Gases
Chemicals
Oil Refining
LNG

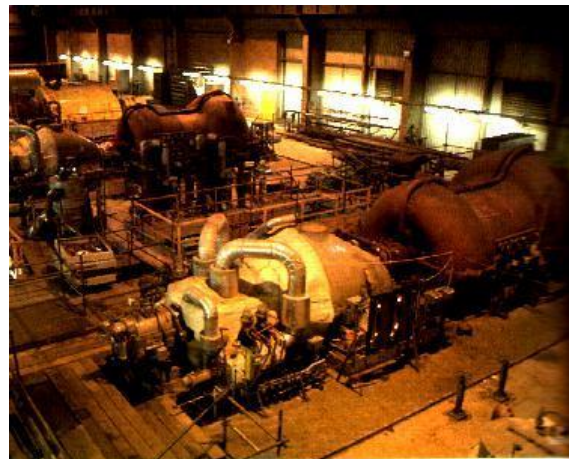

Iron & Steel
Oil & Gas
Power Generation
Water Purification
Aerospace



Flexware®



Turbomachinery Services

- Long term asset monitoring contracts
- Compressors – Turbines - Pumps
- Routine on-site inspections.
- Site survey of equipment efficiency
- Repairs & overhauls
- Experienced equipment specialists
- Troubleshooting equipment problems
- Gas turbine overhauls
- Training programs

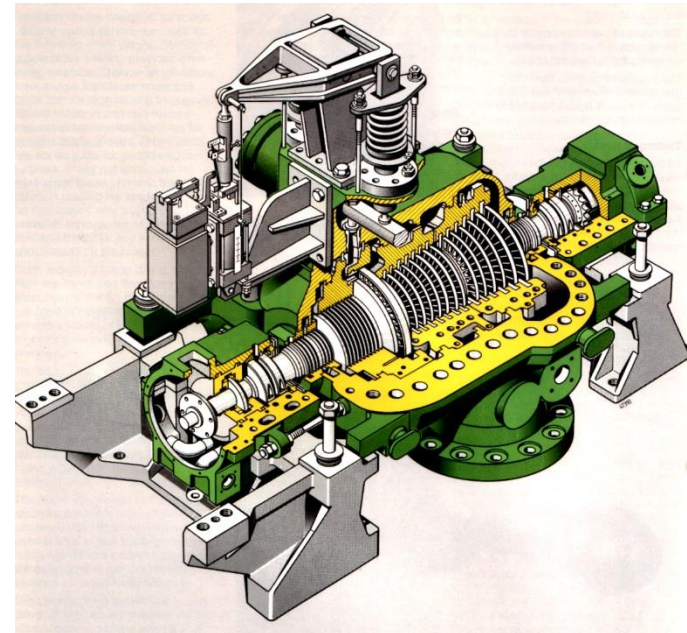



Flexware®



Turbomachinery Mods & Rerates

- Rub tolerant labyrinth seals
- Sleeve seals
- Bearings
- Troubleshooting
- Repairs
- Rerates & Upgrades
- Reverse Engineering
- Replacement parts

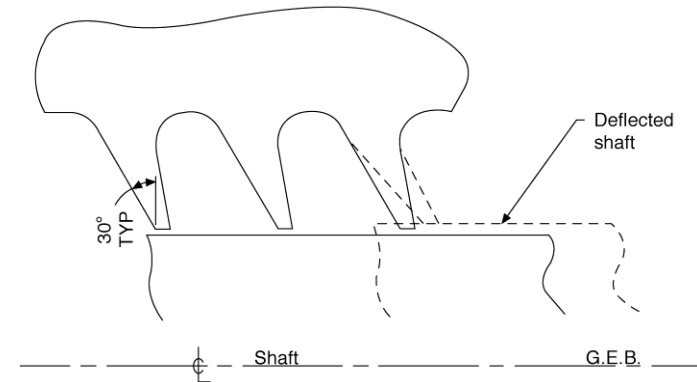



Flexware®



Compressor & Steam Turbine Rerates

- – Aero & Mechanical Engineering Design
- - Hardware
- - Field & Shop Service

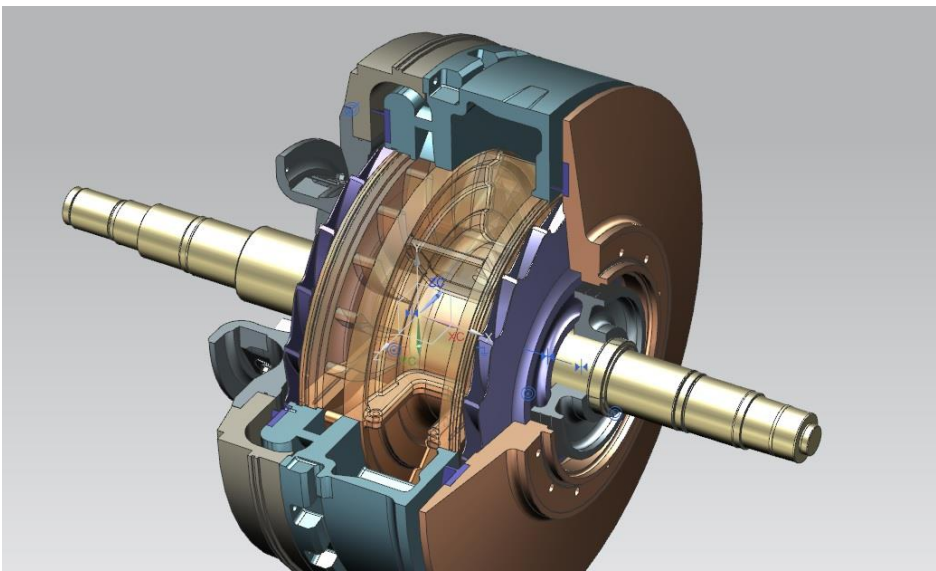

**Rolls Royce RF2BB-36
Rerate:**

- ◆ Increased Head
- ◆ Increased capacity
- ◆ Increased range



Flexware®

Customers

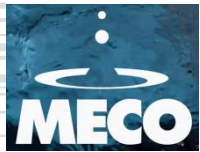
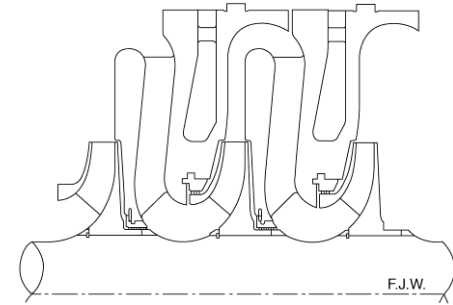

ارامكو السعودية
Saudi Aramco



Bringing energy and the environment into harmony.®

