

# Flexware

A Veteran & Employee Owned Small Business

## Flexware Remote Monitoring Service

Data Monitoring – Analysis - Trending - Forecasting – Diagnostics – Engineering Support

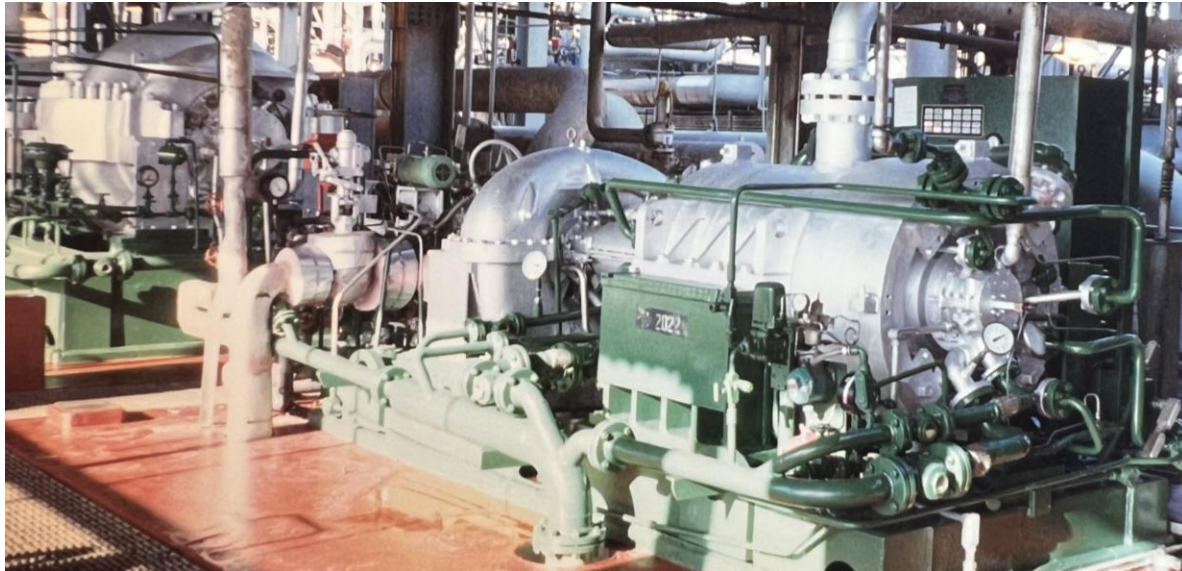

*Providing Turbomachinery Service for over 25 Years*

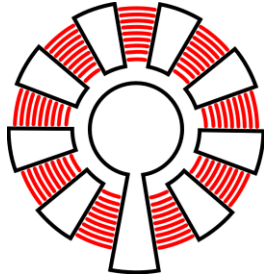

# Flexware

## Flexware

### Remote Monitoring Service

- ◆ Data collection, analysis, presentation, trend and forecast
- ◆ Anomaly detection
- ◆ Situation review and discussion with Flexware Engineers



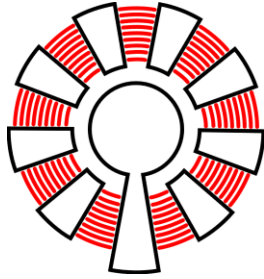

# Flexware

## Flexware

### Remote Monitoring Service:

- ◆ Information is in the cloud
- ◆ Available to the client
- ◆ Available to Flexware Engineers
- ◆ Collaborate on issues remotely
- ◆ Prompt response
- ◆ Remote Collaboration saves money

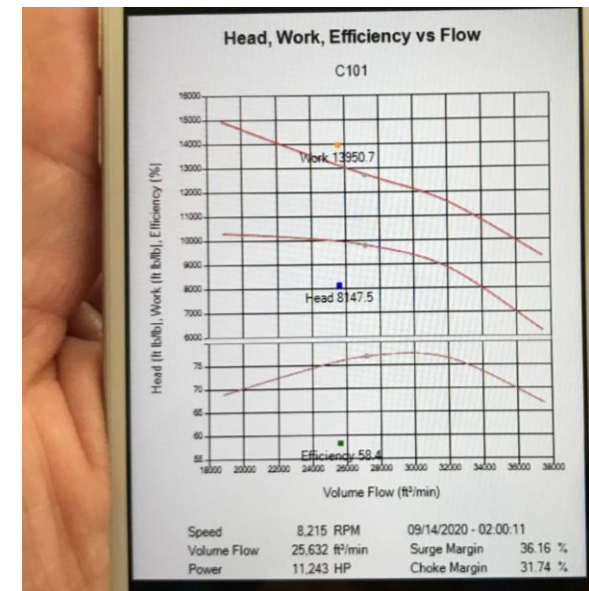

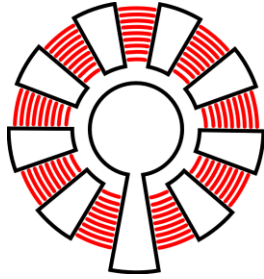

# Flexware

## **Flexware AWM Purchase includes:**

- ◆ Collecting operating data
- ◆ Flexware Engineering staff
- ◆ Rotating equipment Engineers
- ◆ Aerodynamicists
- ◆ Vibration specialists
- ◆ Email – Phone
- ◆ Travel at reasonable rates.





# Flexware

## Engineering Experience

- ◆ Broad based industry experience
- ◆ International experience
- ◆ OEM experience: development, design, & service
- ◆ User experience: operation, maintenance



Petrochemicals  
Industrial Gases  
Chemicals  
Oil Refining  
LNG

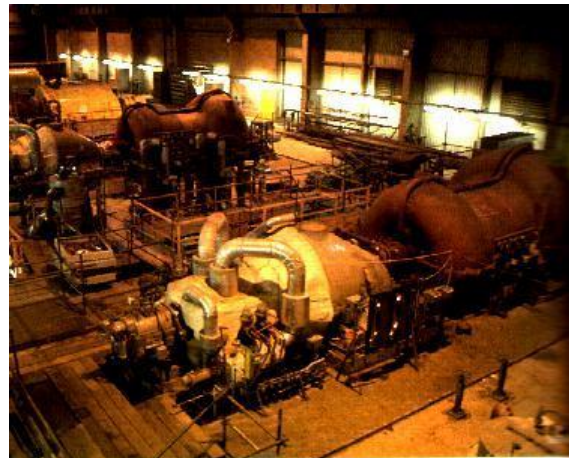

Iron & Steel  
Oil & Gas  
Power Generation  
Water Purification  
Aerospace



# Flexware

## Flexware Engineering staff

- ◆ Seasoned individuals
- ◆ Years of experience.
- ◆ Design
- ◆ Development
- ◆ Service



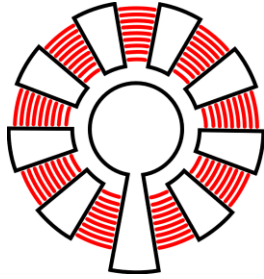

# Flexware

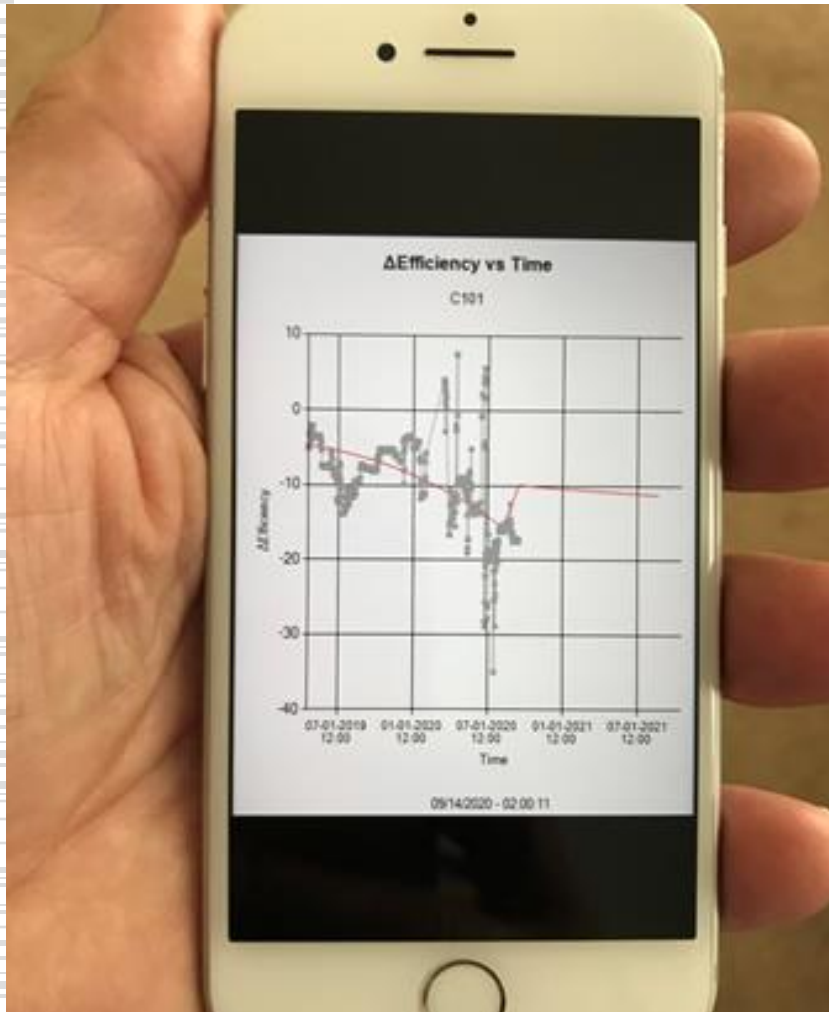

**Turbomachinery health is best assessed by trending and forecasting and collectively assessing:**

- ◆ Delta efficiency (efficiency deviation from predicted values)
- ◆ Vibration
- ◆ Bearing temperatures
- ◆ Thrust position
- ◆ Balance line Pressure drop
- ◆ Seal operating data
- ◆ Oil analysis



# Flexware

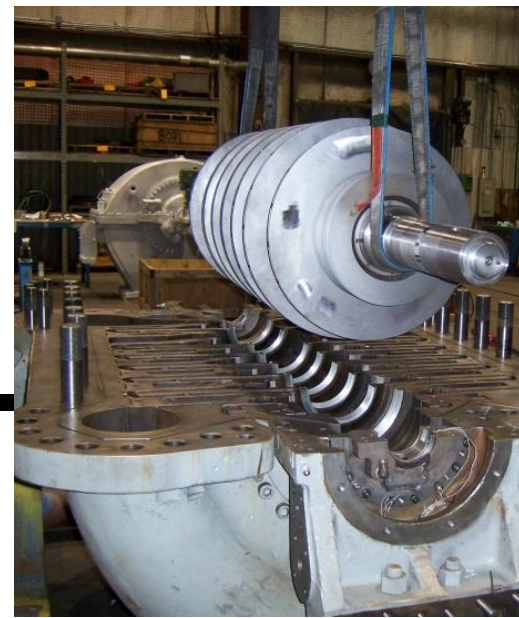

## Flexware Turbomachinery Services

- Flexware Remote Monitoring service
- New equipment design & development
- Service: repairs, mods, parts, rerates & overhauls
- Compressors – Steam Turbines - Gas Turbines – Pumps
- Routine on-site inspections
- Site survey of equipment efficiency
- Troubleshooting equipment problems
- Training programs

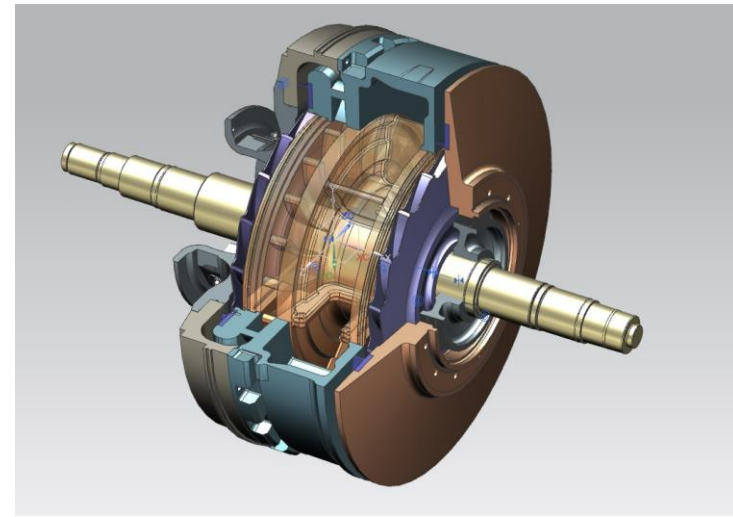

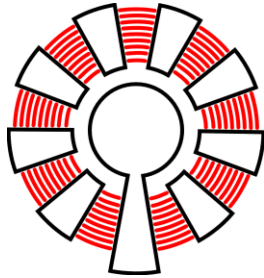

# Flexware

## Customers

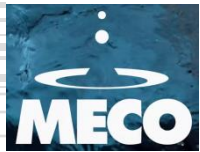

ارامكو السعودية  
Saudi Aramco



**DRESSER-RAND.**

Bringing energy and the environment into harmony.®



ExxonMobil

سابك  
SABIC



sherritt

MOTIVA  
ENTERPRISES LLC

قافكو  
QAFCO  
شركة قطر للأسمدة الكيماوية  
QATAR FERTILISER COMPANY

lyondellbasell

PETROLOGISTICS

NOVA Chemicals

