



# TURBOMACHINERY TRAINING SEMINAR



Turbocompressors – Steam Turbines – Gas Turbines

## “TURBOCOMPRESSORS and their DRIVERS”

Aerodynamics, Bearings & Seals, Couplings, Rotordynamics, Performance Analysis, Troubleshooting & Problem Resolution Thermodynamics, Equipment Selection, Maintenance, Aux. Systems

- Optimize Your Condition Based Equipment Reliability Program
- Maximize Plant Production & Reliability
- Confirm OEM Performance Guarantee
- Optimize Equipment Utilization



[www.johncrane.co.uk](http://www.johncrane.co.uk)

**Flexware**<sup>®</sup> [www.flexwareinc.com](http://www.flexwareinc.com)



Pattaya, Thailand

July 13 - 22, 2010

**TAKE ADVANTAGE OF THIS EXCELLENT OPPORTUNITY TO LEARN COMPRESSOR & TURBINE THEORY AND EASY, PRACTICAL METHODS TO TROUBLESHOOT TURBOMACHINERY.**

**SEMTEC** [www.semtec.ws](http://www.semtec.ws)

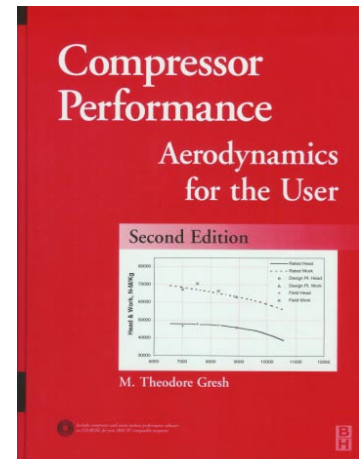

Full system engineering co,ltd.  
[www.fsetech.com](http://www.fsetech.com)

“Notes, book & software are excellent. I still use the notes and text from your course regularly in my work.” Hosam Hassan, Praxair, Toronto

### People Who Should Attend This Seminar

The people attending the course should be technical personnel interested in better understanding turbomachinery (operators, engineers & technicians, reliability specialists, project engineers, equipment specialists and planning engineers).

*“Difficult subject made easy to understand – Excellent work!”  
Showkath Ali K. C., Qatar Petrochemical Co.*

**FOR THE SEASONED ENGINEER AS WELL AS THOSE NEW TO THE SUBJECT OF TURBOMACHINERY.**

### Course Objective

Basic turbomachinery operation and maintenance and easy, practical methods to troubleshoot turbomachinery problems. Improving plant production and reducing maintenance costs.

**Course Materials Includes FREE Software!** Flexware software “Flex Live XK” and “Gas Flex” will be provided along with the book “Compressor Performance” and other printed material. This software normally priced at \$5,000.00 USD, is included with this training program at no additional charge. Flex Live XK software automatically monitors the efficiency of 5 compressor sections and one sidestream compressor.

### Time Schedule & Venue

Seminar duration: 8 days from 8:00 AM to 5:00 PM with lunch break from 12 to 1:00 PM and two 15 minute coffee breaks: one in the morning and one in the afternoon. The Turbomachinery training seminar will be held in Pattaya, Thailand. Contact us for special hotel room rates.

*“I feel your course is very beneficial because of the technical content. It is one step more advanced than a typical OEM course ...” Yuthana Preechalai, PTT Aromatics and Refining, PLC, Rayong, Thailand*

### Program

Following subject areas are covered over an eight-day period in this 2 segment program. A tentative schedule is shown below.

*“...All in all the course is excellent with a lot of valuable information being transmitted.”  
Scott Schultz, Chart Energy & Chemicals, The Woodlands, Texas*

#### 1) Day 1 through Day 4 - Turbocompressor Aerodynamics

**Introduction to Turbocompressors:** Definition of compressor. Types of compressors. Relative comparisons of various compressor types.

**Aerodynamic Components:** Axial compressors. Centrifugal compressors. Impellers, diaphragms, guide vanes. Interstage seals. Balance piston seal. Impeller thrust. Internal compressor configuration: Straight thru, double flow, back to back, multi-stage iso-cool, side-load.

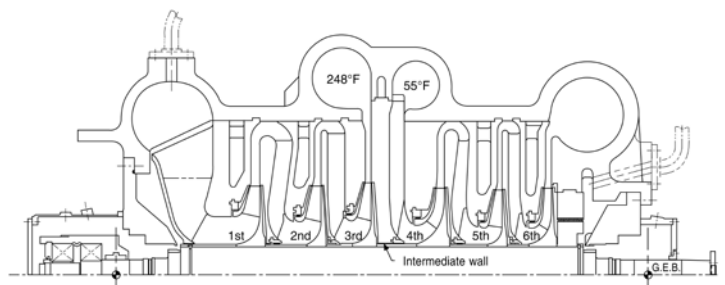

**Compressor Characteristics:** Centrifugal compressors. Slope. Stonewall. Surge. Off-design operation. Influence of the different operating variables: suction pressure, suction temperature, molecular weight changes, rotational speed, etc.

**Compressor Design & Construction:** Casing, impellers, diaphragms & rotors.

**Compressor Performance:** Head & efficiency evaluation

**Equipment Selection:** Considerations for selecting new equipment and rerating existing.

**Compressor Performance – Evaluation & Troubleshooting:** Head & efficiency evaluation, performance problems, solutions and troubleshooting techniques.

**Case Studies:** Aerodynamic problems, iso-cooled compressors, refrigeration compressors, shop & field problems.

**Q & A:** Review in detail questions about aerodynamic issues and go over specific questions and problems brought to the training seminar.



Root Cause Failure Analysis

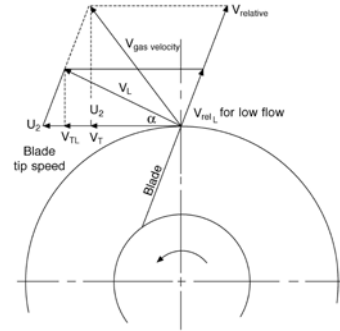

Vector Diagrams

*"Learned a lot!" Jasmin Tremblay, Ultramar (Valero), St. Romuald, Quebec*

## 2) Day 5 through Day 8 - Turbocompressor Drivers, Hardware and Auxiliary Systems: Maintenance & Operation, Bearings, Seals

**Shaft Ends Seals:** Different type of seals: Labyrinth, restrictive (carbon), mechanical contact, sleeve (restrictive bushing) and dry gas seals and buffer systems.

**Journal and Thrust Bearings:** Different type of journal bearings: plain, pressure dam and tilting pad. Tilting pad thrust bearings. Bearing installation. Bearing instrumentation. Bearing damage.

**Vibration:** Vibration limits for turbomachinery & case studies.

**Balance:** Low speed balance, High speed balance.

**Rotor Design, Rotordynamics & Rotor Stability:** Terms definitions, Unbalance critical speed map. Unbalance response analysis. Modal analysis. Rotor Stability

**Couplings:** Types of couplings, required pullup, assembly and disassembly procedures.

**Lube & Seal Oil Systems:** Design philosophy, basic components: reservoir, pumps, relief valves, back-pressure regulator, transfer valve, coolers, filters, instrumentation, temperature control valve, pressure reducing valves, differential pressure reducing valves, contaminated oil drainers, lube rundown tanks, seal rundown tanks, accumulators, degassing tanks, overhead seal tanks, purifiers & piping.

**Turbomachinery Maintenance:** Reliability Strategies, Assembly & Disassembly procedures, Modernization Strategies.

**Troubleshooting & Case Studies:** Mechanical failures, vibration, stability & seal problems

**Compressor and Turbine Operation:** Commissioning. Start-up procedure of compressors for different type of drivers: steam turbines, gas turbines and electric motors. Operational cares. Avoiding liquid ingestion. Possible problems when operating outside the OEM performance curve.

**Turbomachinery Reliability:** Preventive and predictive maintenance.

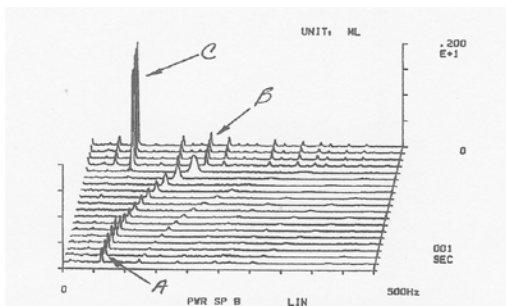

Aerodynamic Instability

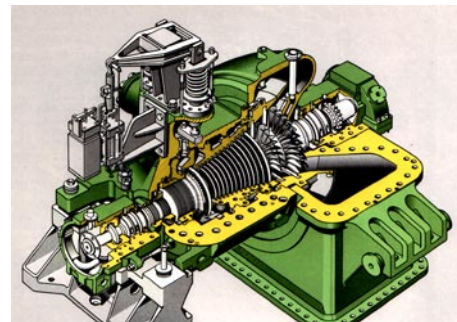

Condensing Steam Turbine

*"..overall good job." Damien Parson, Occidental Chemical, Geismar, Louisiana*

**Introduction to Steam Turbines:** Blade designs, trip & throttle valves, integral rotor forgings, electronic speed control & trip, Rankine cycle, reaction & impulse turbines, back pressure and condensing turbines.

**Casing & Rotors:** Casing, steam chest, inlet valves, diaphragms, extraction valves, nozzle ring solid rotors, built-up rotors.

**Auxiliary Systems:** Speed control, overspeed trip, gland seal systems, condensers

**Operation:** Installation, commissioning & initial startup, operation, maintenance.

**Performance Analysis:** Performance analysis techniques, backpressure turbine analysis, condensing turbine analysis,

**Gas Turbines Overview:** Thermodynamic cycle, single and split shaft turbines, the regenerative cycle, types of gas turbines.

**Axial Compressors:** Axial compressor components, performance characteristics, reaction, off-design operation: rotating stall, surge & choke.

**Gas Turbines Components:** Axial compressor, combustion chamber, gas generator turbine, power turbine.

**Performance Characteristics:** Thermal efficiency vs firing temperature, ambient conditions effect on performance, water & steam injection, inlet air cooling, compressor fouling, recoverable & nonrecoverable losses.

**Q & A:** Review in detail questions about driver and mechanical issues and go over specific questions and problems brought to the seminar.

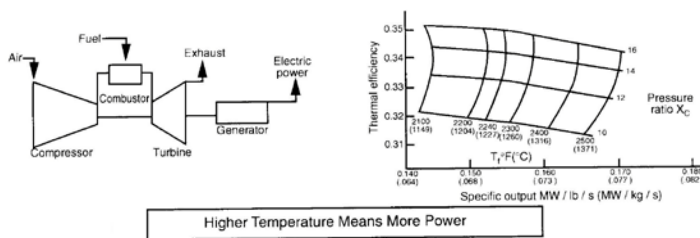
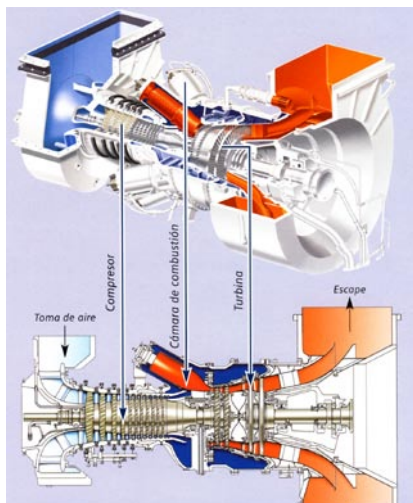

Gas Turbine

*"Nice lecture & content. Helpful to my future work." Frank Yuan, Chart Energy & Chemicals, The Woodlands, Texas*

**Instructors:**



**Anibal R. Arias** is President and Technical Director of **SEMTEC**, a company specialized in Turbomachinery and its Associated Systems. Mr. Arias has worked 19 years for Petroquímica Bahía Blanca, an ethylene producer located in Argentina. During this time he was responsible for Preventive and Predictive Maintenance of Rotating Machinery; Maintenance Engineering and before resigning from the petrochemical company he was Mechanical Maintenance Manager.

In his past professional experience from 1975 to 2001, Mr. Arias taught engineering courses in Universidad Nacional del Sur. Before resigning from this position, he was Adjunct Professor of Machine Elements course. In 1990 he founded **SEMTEC**. Since then he has conducted numerous seminars and workshops on technical and maintenance organization matters in Argentina and around the world including "Compressor Performance Seminar".

Mr. Arias has a Mechanical Engineering Degree from Universidad Nacional del Sur and has extensive hands-on technical training in the USA with Davy-Mc Kee Corporation and Elliott Company. He is a member of ASME, The Vibration Institute and the Society of Tribologist and Lubrication Engineers. You can contact Mr. Arias at: [semtec@speedy.com.ar](mailto:semtec@speedy.com.ar)

**Ted Gresh** is President & CEO of Flexware, Inc., Grapeville, Pennsylvania, U.S.A. Mr. Gresh does consulting work, organizes turbomachinery training seminars and is technical director of Flexware software maintenance and upgrade and other engineering activities.



While at Elliott Co., Jeannette, PA, USA, he was Sr. Design Engineer in charge of the design of centrifugal compressors. During this period he was involved in the design of new centrifugal compressor staging, oil seal redesign as well as the resolution of various shop problems. As Sr. Compressor Service Engineer at Elliott Co. he was involved with the field-testing of compressors and steam turbines and troubleshooting various field problems like performance issues, bearing and seal problems and vibration problems including rotor instability problems.

Gresh received a B.S. degree (Aerospace Engineering, 1971) from the University of Pittsburgh. In addition to numerous papers and magazine articles, he has published a book on the subject of compressor performance, and has several patents related to turbomachinery. He is a member of ASME and a registered Professional Engineer in the State of Pennsylvania. You can contact Mr. Gresh at his e-mail address: [mtgresh@flexwareinc.com](mailto:mtgresh@flexwareinc.com)

*"Thank you for the heat balance methodology for condensing turbines. I can save some money for Shell with that." Clay Crook, Sarawak Shell Berhad*

For further information contact:



**Flexware, Inc.**, PO Box 110, Grapeville, PA 15634-0110, USA, Phone: 1-724-527-3911, Fax: 1-724-527-5701, [sales@flexwareinc.com](mailto:sales@flexwareinc.com), [www.flexwareinc.com](http://www.flexwareinc.com)

*"This seminar enabled us to get more insightful on compressors." V. Govindarajan, John Crane Malaysia*

**Client Listing:** Aramco, British Petroleum, Chart Energy & Chemicals, ConocoPhillips, Consumer Coop Refineries, Dakota Gasification, Dibran GmbH, ExxonMobil, Foster Wheeler, Full System Engineering, GE Oil & Gas, John Crane, Kop-Flex, Linde Engineering, Motiva, Occidental Chemical, Orinoco Iron, Petro-Canada, PDVSA, Praxair, PTT Exploration & Production Co., Qatar Petrochemical Co., RasGas, Shell Chemical, Sherritt Metals, Sincor, Sunoco, Syncrude Canada, Tata Chemicals, Valero

# Flexware® Live Analysis Online Field Performance Monitoring

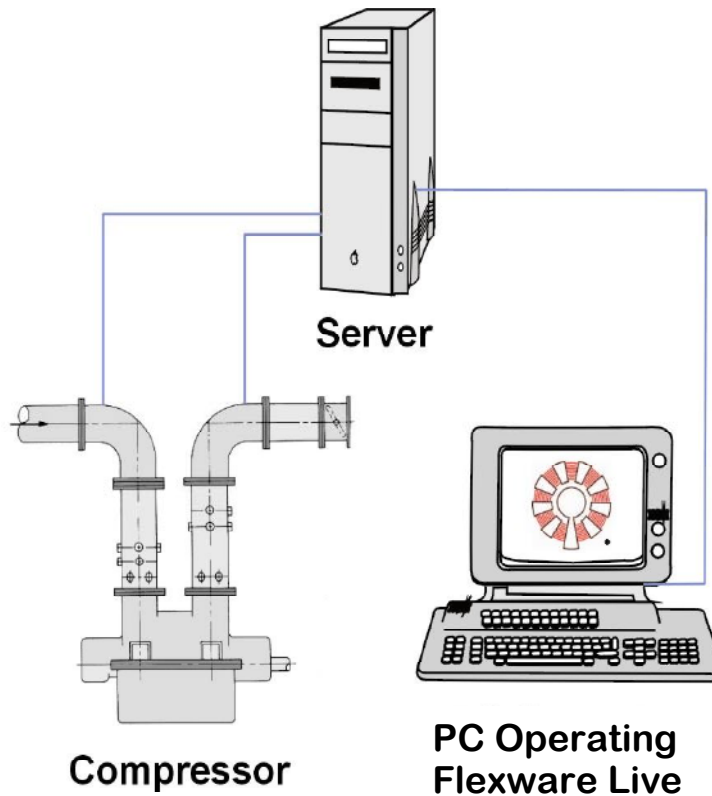

- BWR Accuracy
- “At a Glance” PTC-10 Quality Analysis
- Confirm OEM Guarantees for:
  - New Equipment
  - Upgrades and Rerates
- Demonstrate Effectiveness of Overhauls
- Monitor Performance During Transients

- Condition Based Maintenance
- See where the Compressor is Operating on the Performance Curve
- Aid in Troubleshooting
- Avoid Choke & Surge
- Debottlenecking
- Maximize Plant Capacity

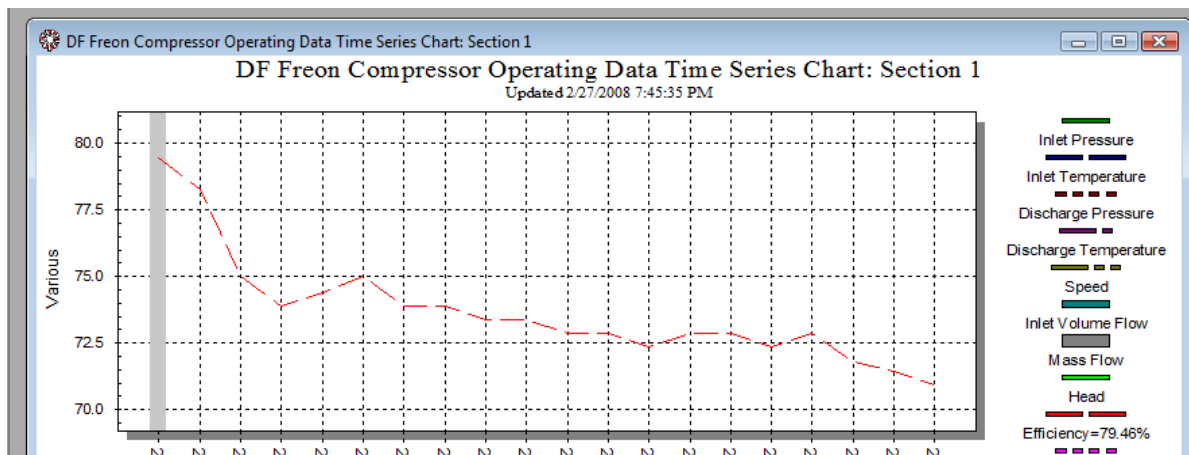

# Monitoring Turbomachinery Performance

- **Maximize plant capacity and minimize costs by providing information for scheduling condition based maintenance**
  - *Cleaning/washing compressor*
  - *Evaluate needs/timing for overhaul*
  - *Maintain maximum plant capacity*
  - *Immediately confirm effectiveness of overhaul or rerate*
- **Confirm OEM guaranteed performance**
- **Avoid choke and surge areas**
- **Aid in plant debottlenecking**
- **Aid in root cause analysis of compressor problems**

Continuous monitoring of compressor performance with Flexware® Live software is an important part of a machinery reliability and condition based maintenance program. Having continuous performance data is essential to knowing how the machinery is operating and what the trends are.

## Condition Based Maintenance

Maximize the output of your plant while minimizing the operating costs. Accurately know the condition of your critical rotating equipment. Do maintenance on your critical equipment when it is needed, but not before. Maximize operating time, reduce power consumption and minimize maintenance costs.

## Surge & Choke Margin

Surge and Choke are areas of operation to be avoided to assure long term reliable operation of your compressor. Flexware® Live monitors the surge and choke margins to assure the compressor is operating within the performance curve limits. Operation in the choke region, especially when liquids may be involved can result in equipment failure.

## Gas Properties

Gas Flex®, first developed as a DOS program in 1990 for use on PC's, has been designed to do gas compressor performance calculations in the most accurate method possible. Some of the more simple procedures are accurate enough for air and some light mole weight gases at moderate pressures and temperatures, but for heavy hydrocarbon gases like refrigerants, gas mixtures at high pressures and temperatures, more complex procedures are required. Flexware® chose to use BWR (Benedict, Webb & Rubin) equations as they are respected in the industry as the most accurate. Flex Live® uses BWR gas equations exclusively for the most accurate results possible.

## Flexware® Live

In its present form, Flexware® Live works with Gas Flex® to continuously process data from compressors via the plant data collection system. Flexware® Live is set up to read data from an Excel spread sheet or

directly connected to a Windows based data source and output to a historical data file and graphical display so you can “see” the results as they occur.

DF Freon Head, Work and Efficiency vs. Flow Chart  
Inlet updated 2/27/2008 11:28:08 AM

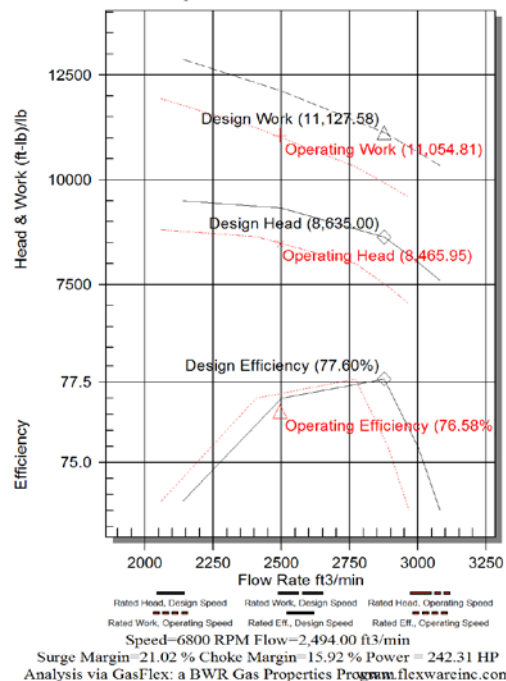

## Trending Data

Data is compared to the OEM performance curve and trended over time. Differential values like the difference in actual operating efficiency compared to the OEM predicted efficiency can be monitored on a time trending basis.

The trending can be especially valuable for monitoring compressor efficiency as a compressor fouls or you can see how the performance changes following an overhaul especially when efficiency improvements like improved interstage seals are incorporated. The result of plant process changes to the compressor will instantly be observed. Transients like hard startups or trips trigger Flexware® Live to increase processing rates to assure capture of the upset condition and thus aid troubleshooting efforts should that be required.

## Registration Form #1004

**Flexware, Inc.,** P.O. Box 110, Grapeville, PA 15634-0110, U. S. A.

Ph (1) 724-527-3911, Fax (1) 724-527-5701 [sales@flexwareinc.com](mailto:sales@flexwareinc.com), [www.flexwareinc.com](http://www.flexwareinc.com)

Method of Payment: (Check One) Check: \_\_\_\_\_ Bank Transfer: \_\_\_\_\_ PO: \_\_\_\_\_ Credit Card: \_\_\_\_\_

<u>#</u>	<u>Item &amp; Description</u>	<u>Price Each</u>	<u>Quantity</u>	<u>Total Price</u>
	<b><u>“TURBOCOMPRESSORS and their DRIVERS”</u></b> <b>Pattaya, July 13 - 22, 2010</b>			
	<b>1) Compressor Aerodynamics: Day 1 – 4</b> <b>July 13 - 16</b>	\$2,695 USD		
	<b>2) Turbocompressor Drivers &amp; Aux Systems:</b> <b>Days 5 – 8; July 19 - 22.</b>	\$2,695 USD		
	<b>Attend both segments – Compressor Aerodynamics</b> <b>&amp; Drivers: July 13 - 22.</b>	\$4,850 USD		
	<b>subtotal</b>			
	<b>6% Sales Tax (Pennsylvania Locations only)</b> Credit card payment is preferred.			
	<b>Total Amount Due</b>			

**Credit Card:** Number \_\_\_\_\_ Expiration Date: \_\_\_\_\_

Signature: \_\_\_\_\_ (Check One)  
 \_\_\_\_\_  AmExp  Mastercard  Visa

**Name & Address:**

Name: \_\_\_\_\_ Title: \_\_\_\_\_

Company: \_\_\_\_\_

Address: \_\_\_\_\_

City: \_\_\_\_\_ State: \_\_\_\_\_ Postal Code: \_\_\_\_\_

Country: \_\_\_\_\_ email: \_\_\_\_\_

Telephone: \_\_\_\_\_ Fax: \_\_\_\_\_

