



TURBOMACHINERY TRAINING SEMINAR



“TURBOMACHINERY PERFORMANCE”

**Aerodynamics, Maintenance, Performance Analysis,
Troubleshooting & Problem Resolution**

SEMTEC www.semtec.ws

- Optimize Your Condition Based Equipment Reliability Program
- Maximize Plant Production & Reliability
- Confirm OEM Performance Guarantee
- Optimize Equipment Utilization

Flexware[®] www.flexwareinc.com



Quebec City

March 19 - 22, 2012

**TAKE ADVANTAGE OF THIS
EXCELLENT OPPORTUNITY TO LEARN
COMPRESSOR & TURBINE THEORY
AND EASY, PRACTICAL METHODS TO
TROUBLESHOOT TURBOMACHINERY.**

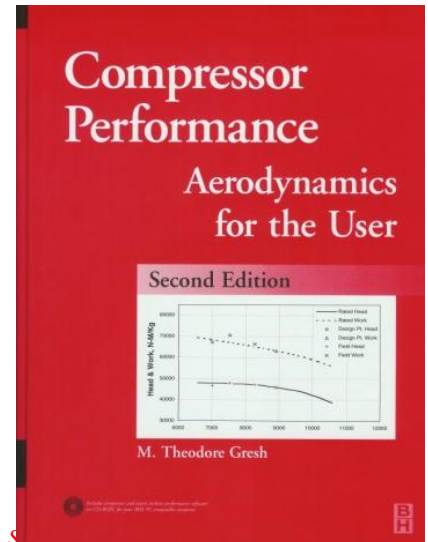

"Good Seminar. Improves my analytical knowledge. Will save the company money & time." S

People Who Should Attend This Seminar

The people attending the course should be technical personnel interested in better understanding turbomachinery (operators, engineers & technicians, reliability specialists, project engineers, equipment specialists and planning engineers).

*"Difficult subject made easy to understand – Excellent work!"
Showkath Ali K. C., Qatar Petrochemical Co.*

**FOR THE SEASONED ENGINEER AS
WELL AS THOSE NEW TO THE
SUBJECT OF TURBOMACHINERY.**

Course Objective

Basic turbomachinery operation and maintenance and easy, practical methods to troubleshoot turbomachinery problems. Improving plant production and reducing maintenance costs.

Course Materials Includes FREE Software! Flexware software “Flex Live XK” and “Gas Flex” will be provided along with the book “Compressor Performance” and other printed material. This software normally priced at \$5,495.00 USD, is included with this training program at no additional charge. Flex Live XK software automatically monitors the efficiency of 5 compressor sections and one sidestream compressor.

Time Schedule & Venue

The seminar will be held at the Valero Quebec City Refinery, 165 Chemin des Iles, Saint-Romuald, Quebec, Canada. Seminar duration: 4 days from 8:00 AM to 5:00 PM with lunch break from 12 to 1:00 PM and two 15 minute coffee breaks: one in the morning and one in the afternoon.

"Notes, book & software are excellent. I still use the notes and text from your course regularly in my work." Hosam Hassan, Praxair, Toronto

Program

Following subject areas are covered over a four-day program. A tentative schedule is shown below.

*"...All in all the course is excellent with a lot of valuable information being transmitted."
Scott Schultz, Chart Energy & Chemicals, The Woodlands, Texas*

Day 1 through Day 4 - Turbocompressor Aerodynamics

Introduction to Turbocompressors: Some firsts, Definition of compressor. Types of compressors. Relative comparisons of compressor types.

Thermodynamics: Gas laws, Thermodynamic relations, Head, Work, Efficiency, Gas mixtures, BWR equations of state, Performance coefficients.

Aerodynamic Components: Axial compressors. Centrifugal compressors. Impellers, diaphragms, guide vanes. Interstage seals. Balance piston seal. Impeller thrust. Internal compressor configuration: Straight thru, double flow, back to back, multi-stage iso-cool, side-load.

Compressor Characteristics: Centrifugal compressors. Slope. Stonewall. Surge. Off-design operation. Adjustable vanes. Influence of the different operating variables: suction pressure, suction temperature, molecular weight changes, rotational speed, etc.

Compressor Design & Construction: Casing, impellers, diaphragms & rotors.

Compressor Performance: Head & efficiency evaluation



Equipment Selection: Considerations for selecting new equipment and rerating existing.

Compressor Operation: Commissioning. Start-up procedure of compressors for different type of drivers: steam turbines, gas turbines and electric motors. Operational cares. Avoiding liquid ingestion, surge and choke. Possible problems when operating outside the OEM performance curve. Parallel operation. Inlet piping.

Axial Compressors: Axial compressor components, performance characteristics, reaction, off-design operation: rotating stall, surge & choke.

Introduction to Steam Turbines: Blade designs, Rankine cycle, reaction & impulse turbines, back pressure and condensing turbines.

Compressor Performance – Evaluation & Troubleshooting: Head & efficiency evaluation, performance problems, solutions and troubleshooting techniques. OEM shop testing, field test and online monitoring. Gas sampling, Instrumentation, Calculation procedures. Trend analysis. Sample calculations. Special considerations for multi-section compressors: iso-cooled compressors & sidestream compressors.

Flex Live® Software: Installation & setup of Flex Live® software. On line monitoring and compressor evaluation using Flex Live® software. Example problems.

Case Studies: Aerodynamic problems, iso-cooled compressors, refrigeration compressors, shop & field problems. Compressor fouling, on & offline wash techniques.

Q & A: Review in detail questions about aerodynamic issues and go over specific questions and problems brought to the training seminar.



Avoiding Failures

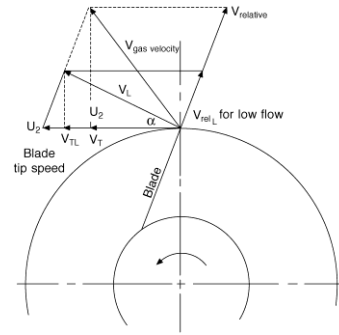

Vector Diagrams

"I learned a lot!" Jasmin Tremblay, Ultramar (Valero), St. Romuald, Quebec

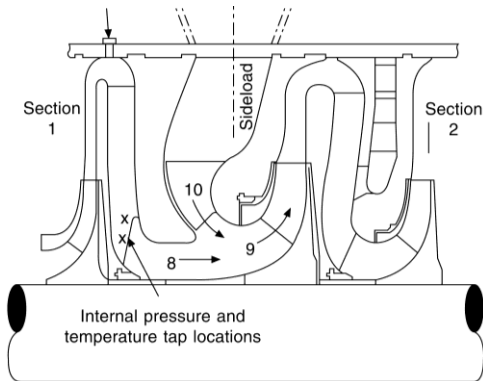

Sideloader Compressor

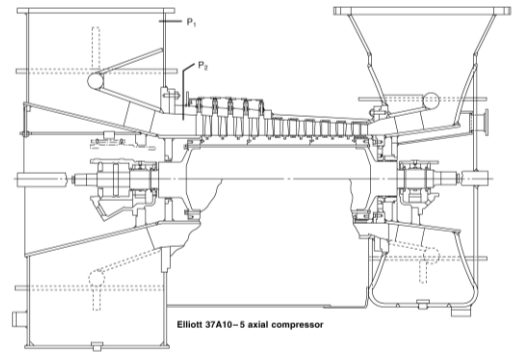

Axial Compressor

"..overall good job." Damien Parson, Occidental Chemical, Geismar, Louisiana

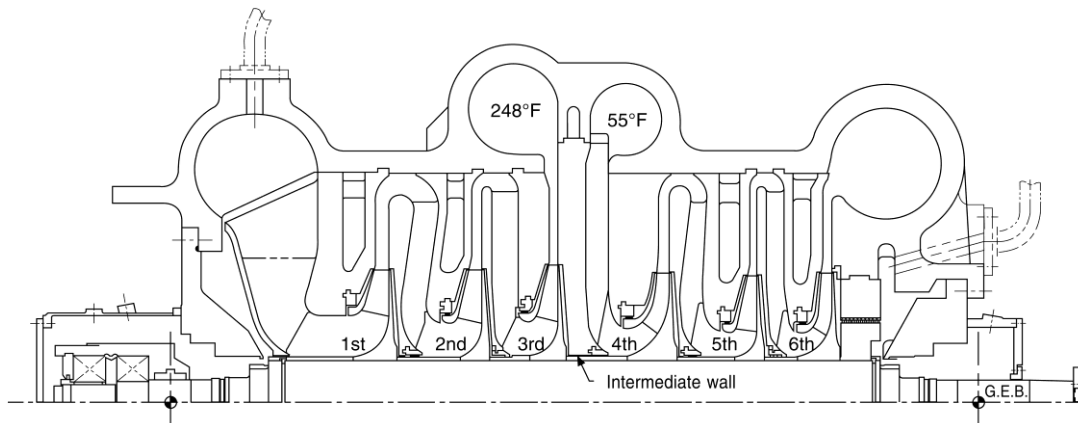

Iso Cooled Compressor

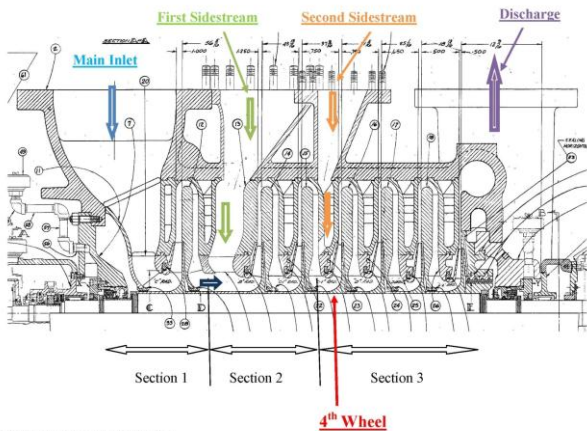

K1 Compressor cross-section

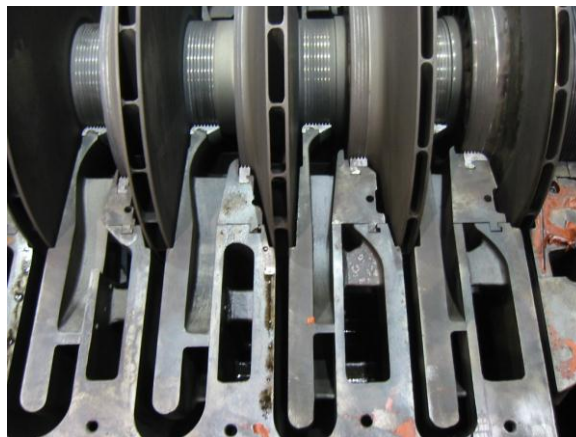

Case Studies: Field Performance Problems

"Nice lecture & content. Helpful to my future work." Frank Yuan, Chart Energy & Chemicals, The Woodlands, Texas

Instructors:



Anibal R. Arias is President and Technical Director of **SEMTEC**, a company specialized in Turbomachinery and its Associated Systems. Mr. Arias has worked 19 years for Petroquímica Bahía Blanca, an ethylene producer located in Argentina. During this time he was responsible for Preventive and Predictive Maintenance of Rotating Machinery; Maintenance Engineering and before resigning from the petrochemical company he was Mechanical Maintenance Manager.

In his past professional experience from 1975 to 2001, Mr. Arias taught engineering courses in Universidad Nacional del Sur. Before resigning from this position, he was Adjunct Professor of Machine Elements course. In 1990 he founded **SEMTEC**. Since then he has conducted numerous seminars and workshops on technical and maintenance organization matters in Argentina and around the world including "Compressor Performance Seminar".

Mr. Arias has a Mechanical Engineering Degree from Universidad Nacional del Sur and has extensive hands-on technical training in the USA with Davy-Mc Kee Corporation and Elliott Company. He is a member of ASME, The Vibration Institute and the Society of Tribologist and Lubrication Engineers. You can contact Mr. Arias at: semtec@speedy.com.ar

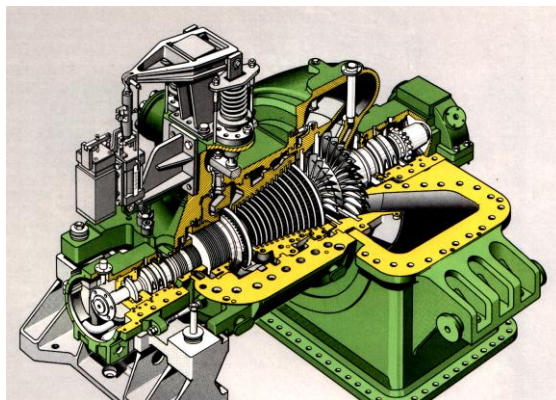

Condensing Steam Turbine

"This seminar enabled us to get more insightful on compressors." V. Govindarajan, John Crane Malaysia

For further information contact:



Flexware, Inc., PO Box 110, Grapeville, PA 15634-0110, USA, Phone: 1-724-527-3911, Fax: 1-724-527-5701, sales@flexwareinc.com, www.flexwareinc.com

"Thank you for the heat balance methodology for condensing turbines. I can save some money for Shell with that." Clay Crook, Sarawak Shell Berhad

Client Listing: Aramco, British Petroleum, Chart Energy & Chemicals, ConocoPhillips, Consumer Coop Refineries, Canadian Natural Resources, Dakota Gasification, Dibran GmbH, ExxonMobil, Foster Wheeler, Full System Engineering, GE Oil & Gas, John Crane, Hess Oil, Kop-Flex, Linde Engineering, Motiva, Occidental Chemical, Orinoco Iron, Petro-Canada, PDVSA, Praxair, PTT Exploration & Production Co., Qatar Petrochemical Co., RasGas, Shell Chemical, Sherritt Metals, Sincor, Sunoco, Syncrude Canada, Tata Chemicals, Valero

Flexware® Live Analysis Online Field Performance Monitoring

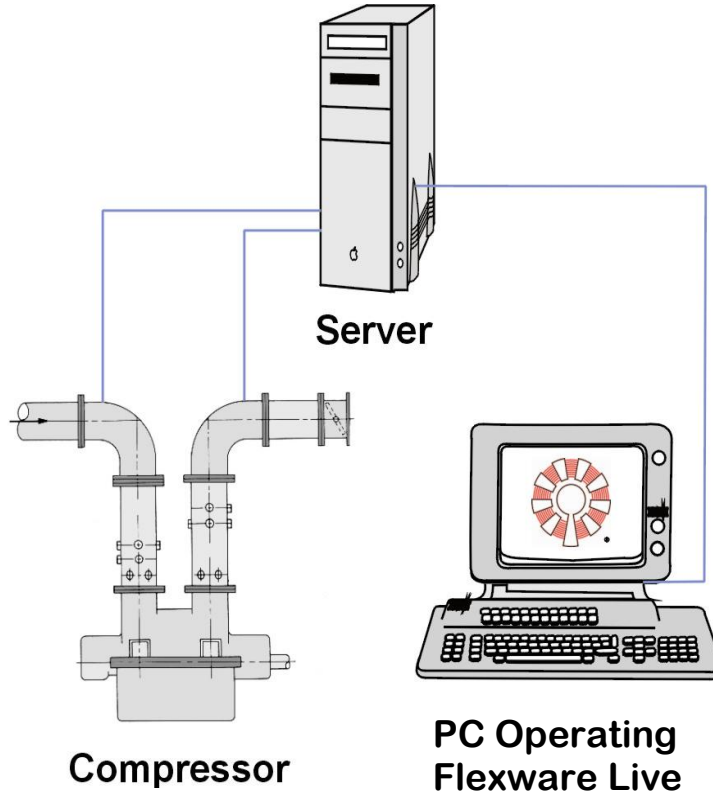

- BWR Accuracy
- “At a Glance” PTC-10 Quality Analysis
- Confirm OEM Guarantees for:
 - New Equipment
 - Upgrades and Rerates
- Demonstrate Effectiveness of Overhauls
- Monitor Performance During Transients

- Condition Based Maintenance
- See where the Compressor is Operating on the Performance Curve
- Aid in Troubleshooting
- Avoid Choke & Surge
- Debottlenecking
- Maximize Plant Capacity

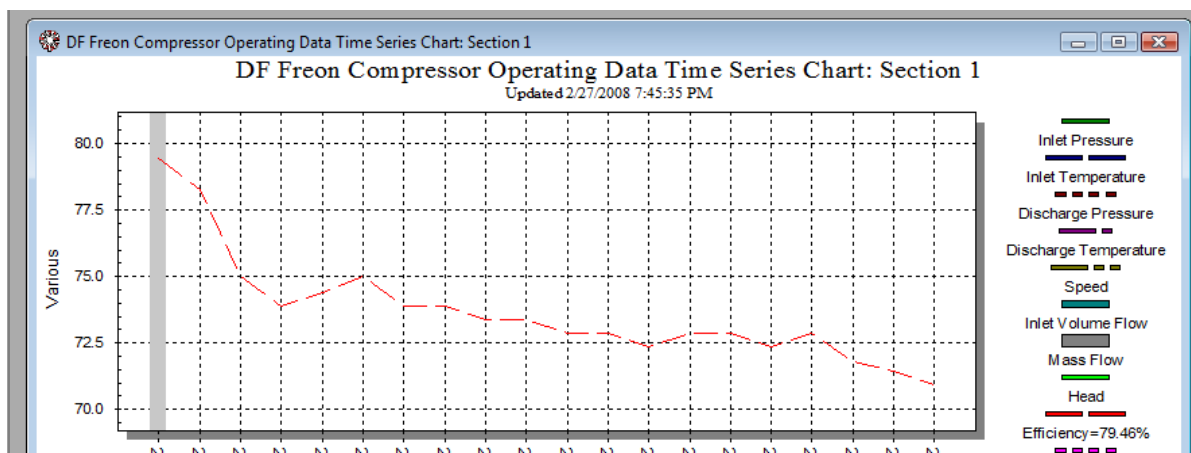

Monitoring Turbomachinery Performance

- **Maximize plant capacity and minimize costs by providing information for scheduling condition based maintenance**
 - *Cleaning/washing compressor*
 - *Evaluate needs/timing for overhaul*
 - *Maintain maximum plant capacity*
 - *Immediately confirm effectiveness of overhaul or rerate*
- **Confirm OEM guaranteed performance**
- **Avoid choke and surge areas**
- **Aid in plant debottlenecking**
- **Aid in root cause analysis of compressor problems**

Continuous monitoring of compressor performance with Flexware® Live software is an important part of a machinery reliability and condition based maintenance program. Having continuous performance data is essential to knowing how the machinery is operating and what the trends are.

Condition Based Maintenance

Maximize the output of your plant while minimizing the operating costs. Accurately know the condition of your critical rotating equipment. Do maintenance on your critical equipment when it is needed, but not before. Maximize operating time, reduce power consumption and minimize maintenance costs.

Surge & Choke Margin

Surge and Choke are areas of operation to be avoided to assure long term reliable operation of your compressor. Flexware® Live monitors the surge and choke margins to assure the compressor is operating within the performance curve limits. Operation in the choke region, especially when liquids may be involved can result in equipment failure.

Gas Properties

Gas Flex®, first developed as a DOS program in 1990 for use on PC's, has been designed to do gas compressor performance calculations in the most accurate method possible. Some of the more simple procedures are accurate enough for air and some light mole weight gases at moderate pressures and temperatures, but for heavy hydrocarbon gases like refrigerants, gas mixtures at high pressures and temperatures, more complex procedures are required. Flexware® chose to use BWR (Benedict, Webb & Rubin) equations as they are respected in the industry as the most accurate. Flex Live® uses BWR gas equations exclusively for the most accurate results possible.

Flexware® Live

In its present form, Flexware® Live works with Gas Flex® to continuously process data from compressors via the plant data collection system. Flexware® Live is set up to read data from an Excel spreadsheet or

directly connected to a Windows based data source and output to a historical data file and graphical display so you can “see” the results as they occur.

DF Freon Head, Work and Efficiency vs. Flow Chart
Inlet updated 2/27/2008 11:28:08 AM

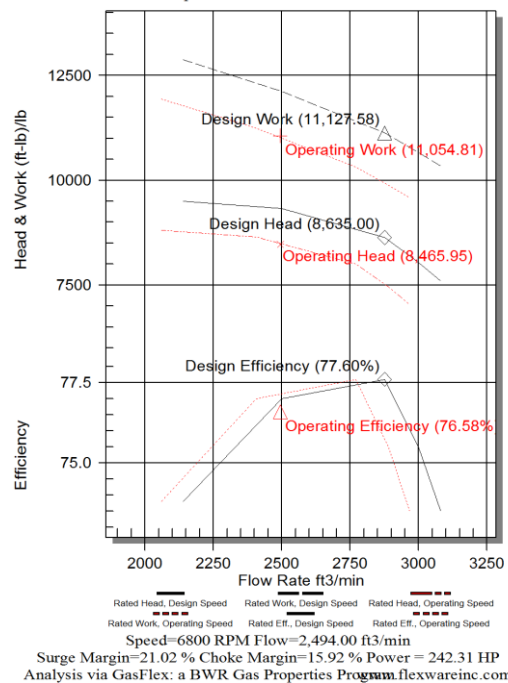

Trending Data

Data is compared to the OEM performance curve and trended over time. Differential values like the difference in actual operating efficiency compared to the OEM predicted efficiency can be monitored on a time trending basis.

The trending can be especially valuable for monitoring compressor efficiency as a compressor fouls or you can see how the performance changes following an overhaul especially when efficiency improvements like improved interstage seals are incorporated. The result of plant process changes to the compressor will instantly be observed. Transients like hard startups or trips trigger Flexware® Live to increase processing rates to assure capture of the upset condition and thus aid troubleshooting efforts should that be required.

Registration Form #1112

Flexware, Inc., P.O. Box 110, Grapeville, PA 15634-0110, U. S. A.

Ph (1) 724-527-3911, Fax (1) 724-527-5701 sales@flexwareinc.com, www.flexwareinc.com

Method of Payment: (Check One) Check: Bank Transfer: PO: Credit Card:

<u>#</u>	<u>Item & Description</u>	<u>Price Each</u>	<u>Quantity</u>	<u>Total Price</u>
	<u>“TURBOMACHINERY PERFORMANCE”</u> Mar 19 - 22, 2012	\$3,150 USD		
	subtotal			
	6% Sales Tax (Pennsylvania Locations only) Credit card payment is preferred.			
	Total Amount Due			

Credit Card: Number _____ Expiration Date: _____

Signature: _____ (Check One) _____ AmExp _____ Mastercard _____ Visa

Name & Address:

Name: _____ Title: _____

Company: _____

Address: _____

City: _____ State: _____ Postal Code: _____

Country: _____ email: _____

Telephone: _____ Fax: _____

